

aluminum systems
albau

Modern Aluminum Closing Solutions



2024

Product Catalog



albau-usa.com

GUILLOTINE GLASS

Insulated & Tempered



Made in USA

About Us

Albau Aluminum & Glass System LLC is a manufacturer of modern aluminum enclosure systems based in New Jersey.



Our dedicated teams specialize in the manufacturing and installation of all the products we offer, providing end-to-end service. We address seasonal issues in your homes and workplaces by creating solutions with modern and intelligent aluminum-glass systems. How?

We design the outdoor space you envision together. In our projects, we use innovative, environmentally friendly, technologically advanced, and smart systems to quickly manufacture them.

We offer these aluminum and glass systems, which can be remotely controlled, integrated with features, with long-term warranties and service support that begins after installation.

Albau Aluminum & Glass System LLC, provides solutions for seasonal problems like movable roof, winter garden, guillotine glass, sliding glass, garden fence, zip curtain and windbreak that can all be integrated with your smart phone so that you can have all the control at your finger tip.

We provide project - manufacturing and assembly services in America and Canada.

It's time to make your dream home and office.

Design

Guillotine window systems are systems where windows open vertically with a remote control.

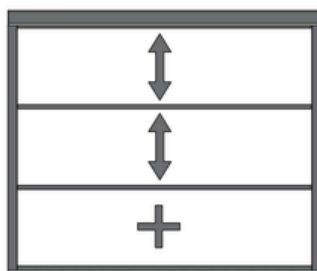

3 Panels Guillotine System

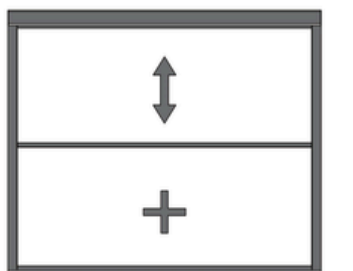

2 Panels Guillotine System

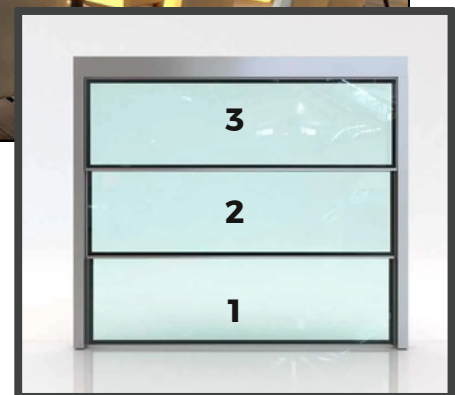

Depending on the measurements and the project, it operates by the vertical opening and closing of 2 or 3 glass panels, overlapping each other.



2 Years
Warranty



4 Seasons
Protection



Smart Systems



Technical
Support



Professional
Quick Assembly

Introduction

Resistant to cracking and breaking with high-strength tempered glass and a sturdy aluminum frame, they are durable against all types of weather conditions.

In smart and technological guillotine window systems, double glazing is used to reduce heat transfer, providing better energy efficiency and sound insulation.

They are easy to clean and hygienic, adding a stylish and modern look to the space.

Fixed panels serve as railings when in the closed position.



Guillotine window systems are used in residences, cafes, restaurants, villas, farmhouses, winter gardens, and many other areas. We can custom manufacture guillotine windows in desired dimensions, offering various color options to match your style.

Primary Systems

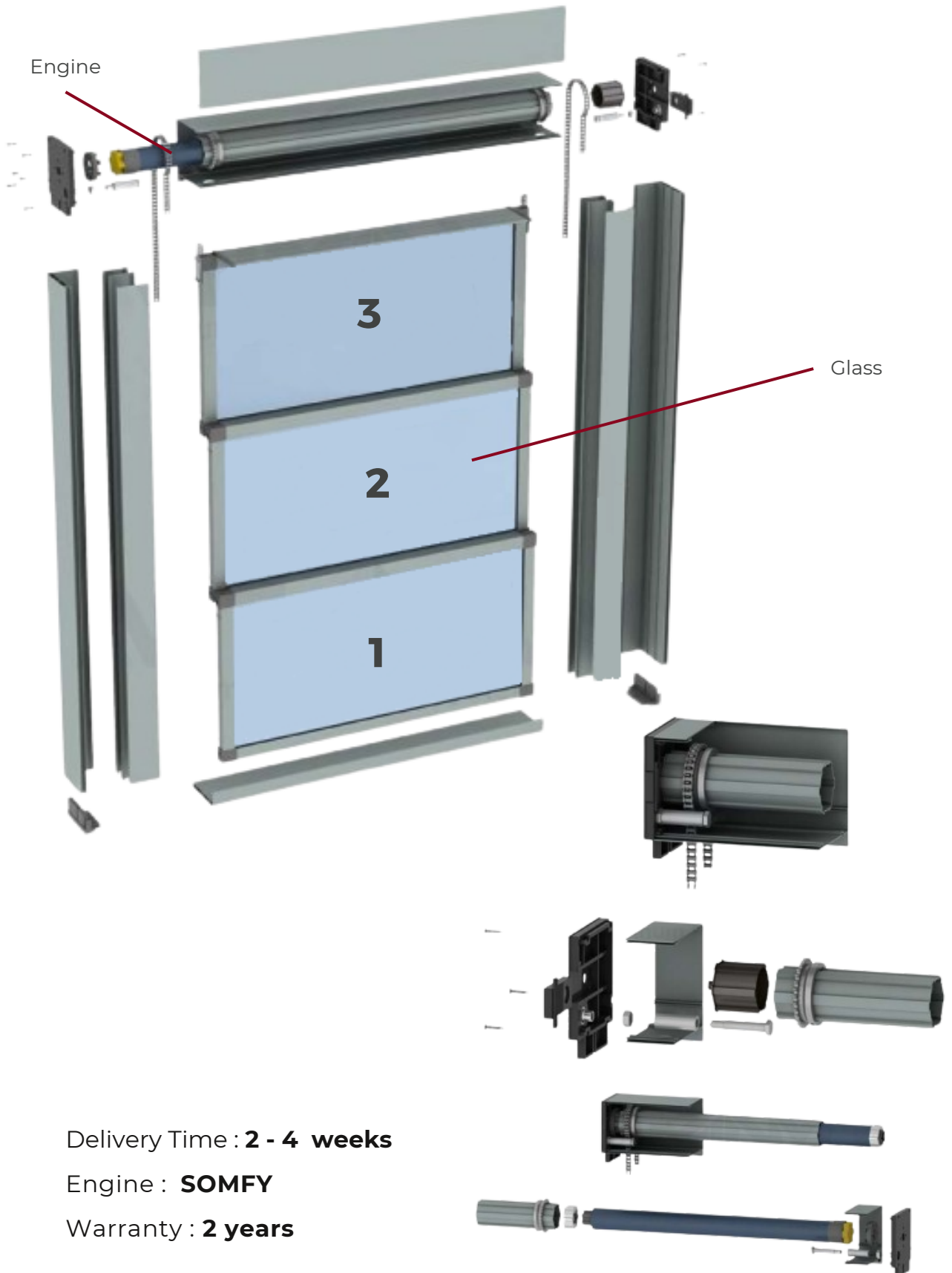

Dimensions

| System | Transmission Part | Properties of Glass | | Motor Properties | | Max. Dimensions | | Rail Width |
|----------|-------------------|----------------------|--|------------------|------------|---------------------|---------------------|-------------------|
| | | Glass Type | Glass Combination | Torque | Revolution | Max. Width | Max. Height | |
| Vision 1 | Chain | Monolithic Glass | 5/16" Tempered (8 mm) | 120 Nm | 11 Rpm | 157,5" (4000 mm) | 137,8" (3500 mm) | 4,33" (110 mm) |
| Vision 2 | Chain | Insulated Glass Unit | 3/16 + 9/16 + 3/16" Tempered (5 +14+5 mm) | 120 Nm | 11 Rpm | 125,9" (3200 mm) | 137,8" (3500 mm) | 4,92" (125 mm) |
| Vision 3 | Chain | Insulated Glass Unit | 3/16 + 9/16 + 3/16" Tempered (5 +14+5 mm) | 120 Nm | 11 Rpm | 125,9" (3200 mm) | 137,8" (3500 mm) | 4,92" (125 mm) |

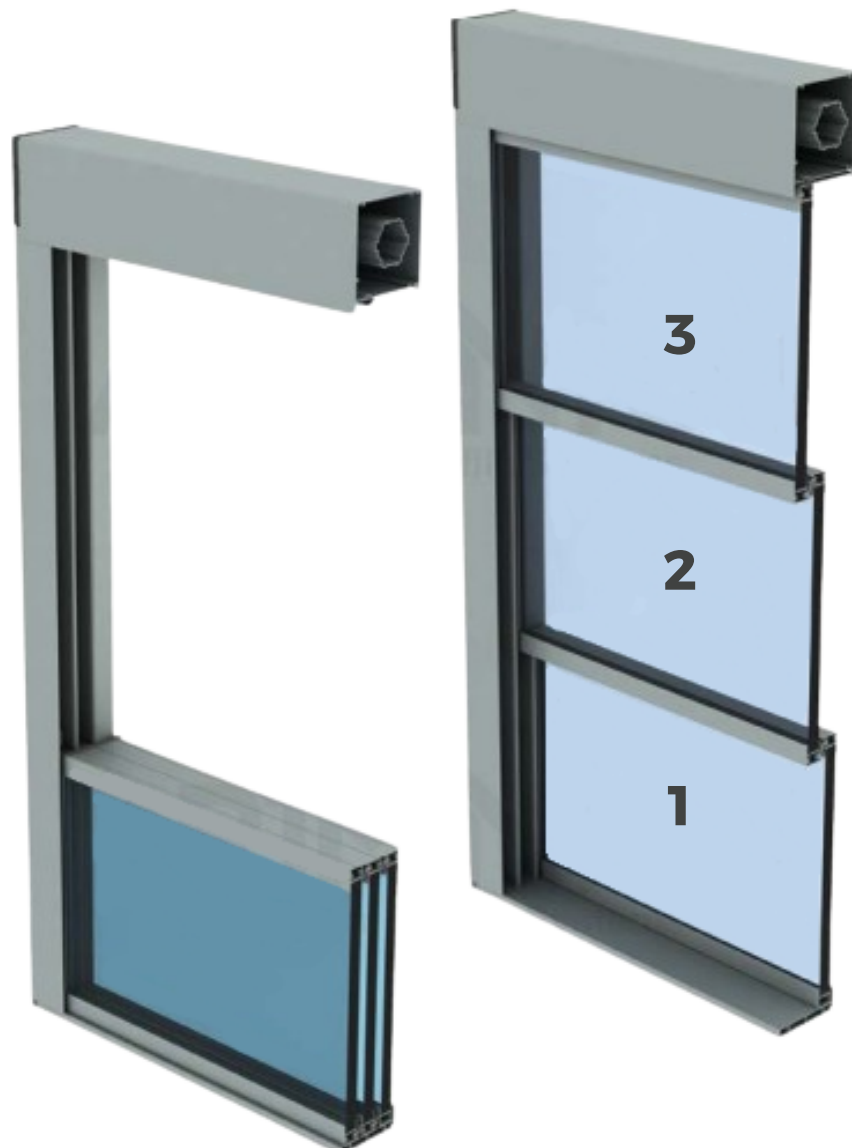

7 **Project Examples**

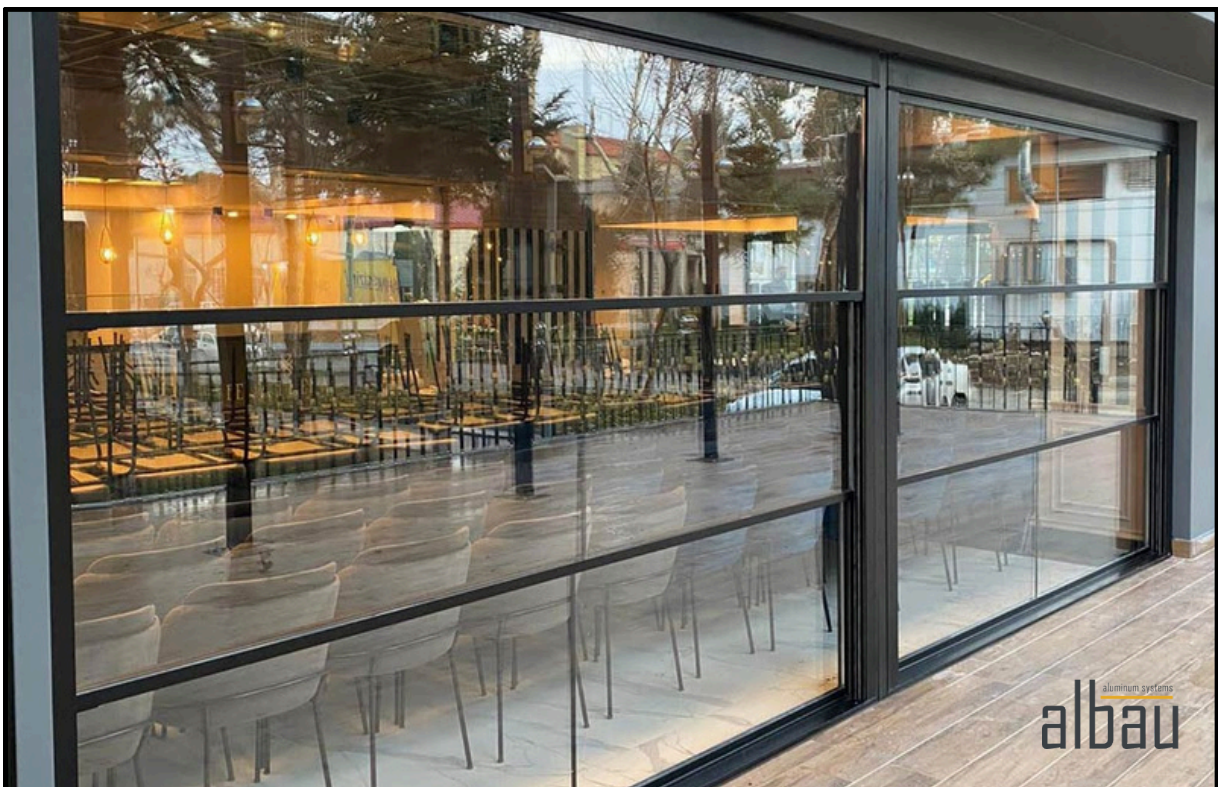
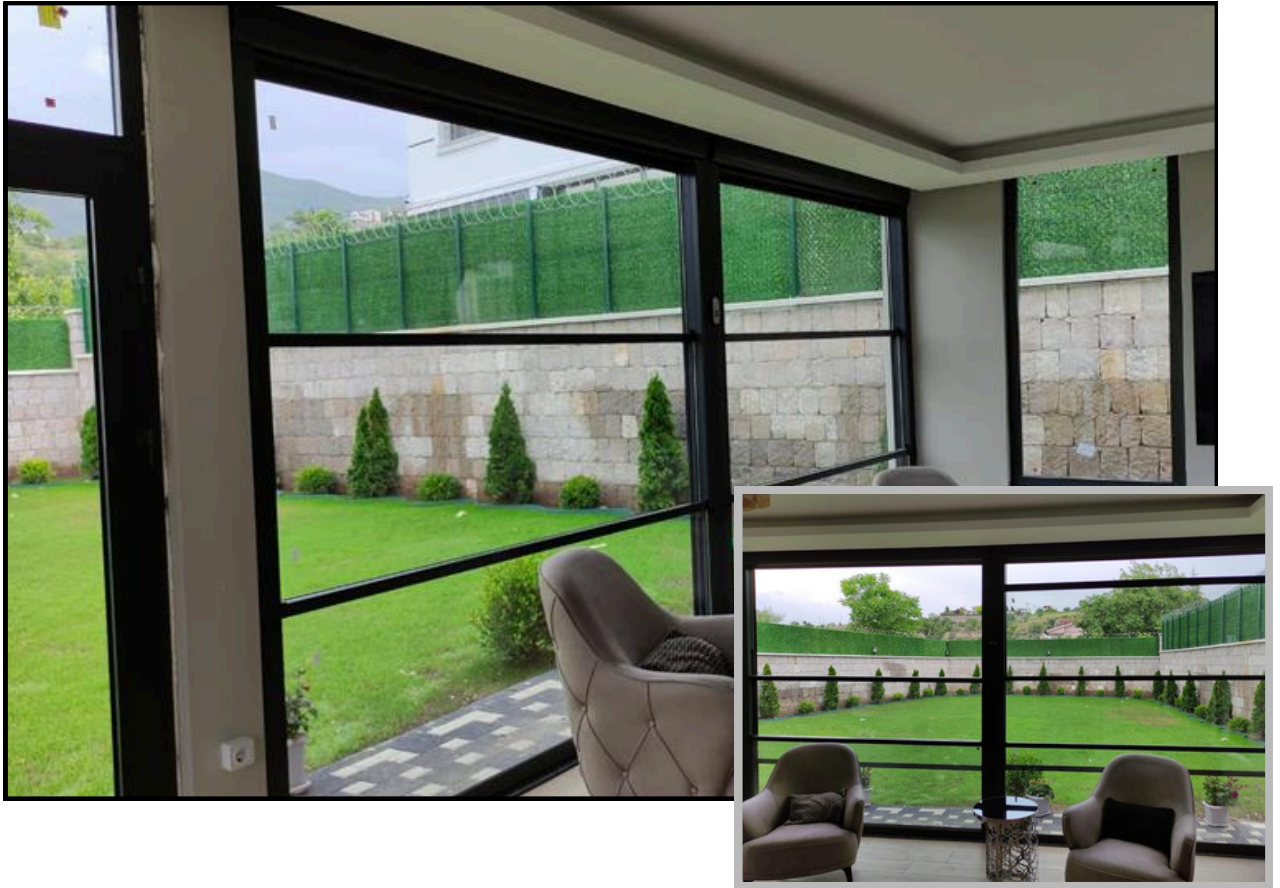

Profile Details



Engine Box Profile
Product Code:37272
Weight kg/m: 2,645
(138 x 160 x 2mm)

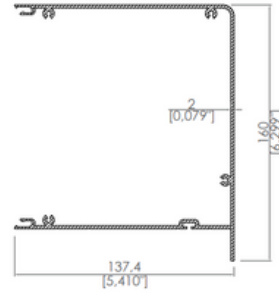

Engine Box Cover Profile
Product Code:37271
Weight kg/m: 0,847
(13 x 145 x 1,8mm)

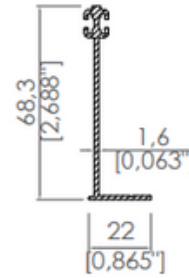

Rail Cover Profile
Product Code:37270
Weight kg/m: 0,230
(13 x 39 x 1,3mm)

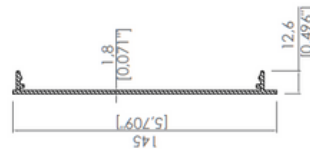

Rail Profile
Product Code:32267
Weight kg/m: 1,624
(84 x 124 x 1,6mm)

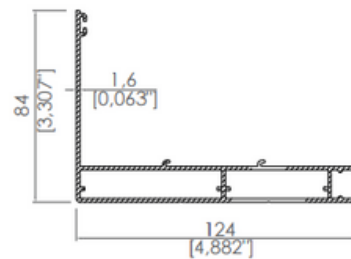

Profile Details



24mm Handrail Profile

Product Code:37265

Weight kg/m: 1,285
(38 x 120 x 1,6mm)

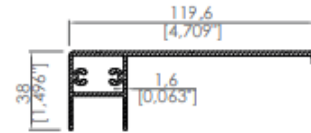

24mm Sewing and Bottom Profile

Product Code:37263

Weight kg/m: 0,545
(28 x 35 x 1,6mm)

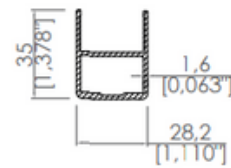

Ray Inner Nail Profile

Product Code:37268

Weight kg/m: 0,464
(22 x 68 x 1,6mm)

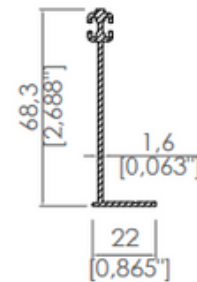

Ray External Nail Profile

Product Code:37269

Weight kg/m: 0,475
(13 x 84 x 1,6mm)

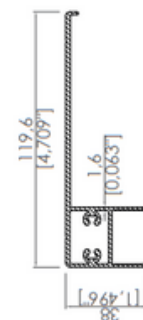

SOMFY RTS 120 NW / 110V engine is used in the systems.

aluminum systems

albau

Modern en Aluminum Closing Solutions

+ 1 (908) - 265 97 40

Office

375 Green St. Teterboro / NJ 07608

Factory

22 Commerce Rd. Unit H Fairfield / NJ 07004

www.albau-usa.com

info@albau-usa.com